



# VARIABLE MULCHER



## RELIABLE & VERSATILE, WHATEVER THE JOB

Suitable for excavators and skid steer loaders, these mulchers are designed and manufactured to handle the toughest clearance applications through to precise hedge trimming.

What really makes this mulcher unique is the option of different drums, so whatever the job at hand you can easily switch between the options, providing the ultimate solution for all your land clearing needs.

### HEAVY DUTY CONSTRUCTION

- ▶ Solid steel structure
- ▶ Low profile design for good visibility
- ▶ Removable side plates for easy belt access
- ▶ Drainage holes for use in bad weather

### HINGED DOOR

- ▶ Adjustable for optimised performance
- ▶ Easy access for maintenance checks
- ▶ Heavy duty hinges & dual locking pins

### HEAVY DUTY BEARINGS & TRIPLE BELT SYSTEM

- ▶ Large bearings for smooth running & reliability
- ▶ Shrouded external greasing points
- ▶ Easy access triple belt system

### REMOVEABLE PUSH BAR & PRESSURE GAUGE

Easily convert from skid steer to excavator operation - remove the push bar & pressure gauge to help save on weight & bulkiness when attached to excavators.

### HEAVY DUTY DRUM - EASILY SWAPPED ON-SITE

- ▶ Drum change on-site with ease for maximum versatility
- ▶ Drums balanced to grade G16 and run 12mm thick sidewalls

### OPTIMISED CUTTING TEETH

- ▶ Designed for optimal strike rate & timing to prevent drum stall & clogging



### FIXED TUNGSTEN TOOTH DRUM

- ▶ The toughest and most versatile option.
- ▶ Suitable for solid timber up to 250mm thick, lighter material like hedges and tree branches.



### SWINGING HAMMER TOOTH DRUM

- ▶ Offers a cleaner cutting performance on soft materials.
- ▶ Ideal for lighter work where clean cutting of soft vegetation is required like reshaping dense hedgerows or processing hedge and branch trimmings into mulch.
- ▶ Capable of mulching smaller trees down to ground.

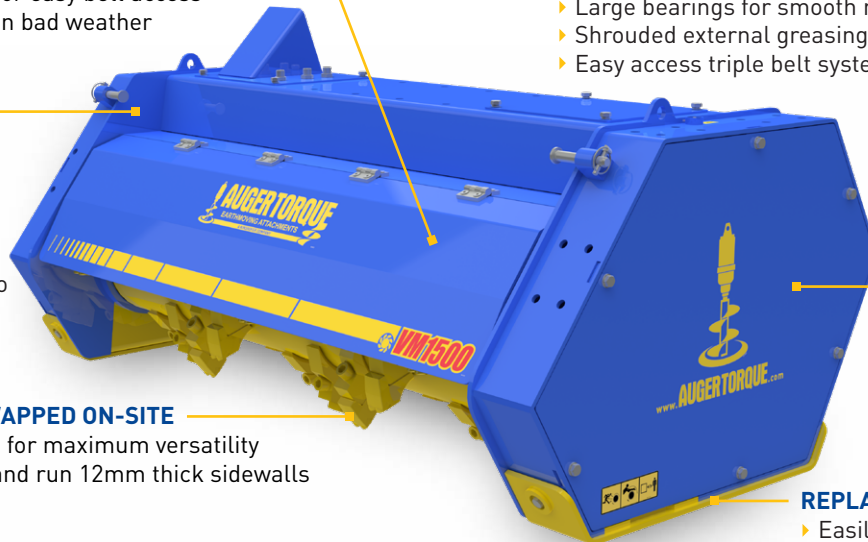

### REPLACEABLE SKID PLATES

- ▶ Easily removed & replaced
- ▶ Also aids drum storage

[www.augertorque.com.au](http://www.augertorque.com.au)

CALL 13 22 12 | EMAIL [sales@augertorque.com.au](mailto:sales@augertorque.com.au)

OR CONTACT YOUR NEAREST DEALER

## Applications

- ▶ Ground clearance
- ▶ Woodland pathway creation and maintenance
- ▶ Clear and maintain vegetation
- ▶ Processing tree and hedge trimmings
- ▶ Mulch trees and hedges down to ground level
- ▶ Fire break creation
- ▶ Compost mulching
- ▶ Hedge maintenance
- ▶ VM1500 suitable for solid timber up to 250mm
- ▶ VM1000 suitable for solid timber up to 120mm
- ▶ Mowing grass and dense bushes
- ▶ Maintenance of roadside vegetation
- ▶ Orchard & vineyard maintenance

## Specifications

### VM1000

#### Standard Gear Motor

Oil Pressure Range: 160 - 180 BAR (2320.6 - 2610.7 psi)

Optimum Oil Pressure: 180 BAR (2610.7 psi)

Oil Flow Range: 60 - 70 LPM (15.85 - 18.49 gpm)

Optimum Oil Flow: 70 LPM (18.49 gpm)

#### SUITABLE FOR EXCAVATORS

5T (11023 lbs) to 10T (22046 lbs)

#### SKIDSTEER COMPATIBLE

Suitable for machines that can obtain the above pressures and flow rates

#### CUTTING

Drum Speed: up to 2400rpm (parent machine dependant)

Cutting drum width: 1000mm (40 in)

Processes trees up to 120 mm (5 in) diameter

#### DIMENSIONS

694mm x 1260mm x 802mm (h x w x d)

27.32in x 49.61in x 31.57in (h x w x d)

#### WEIGHT

400 kg (882 lbs)

### VM1500

#### Standard Piston Motor

Oil Pressure Range: 220- 240 BAR (3190.8 - 3480.9 psi)

Optimum Oil Pressure: 240 BAR (3480.9 psi)

Oil Flow Range: 85 - 95 LPM (22.4 - 25.0 gpm)

Optimum Oil Flow: 95 LPM (25.0 gpm)

#### SUITABLE FOR EXCAVATORS

10T (22046 lbs) to 15T (33069 lbs)

#### SKIDSTEER COMPATIBLE

Suitable for machines that can obtain the above pressures and flow rates

#### CUTTING

Drum Speed: up to 2400rpm (parent machine dependant)

Cutting drum width: 1500mm (60 in)

Processes trees up to 250 mm (10 in) diameter

#### DIMENSIONS

865mm x 1830mm x 1002mm (h x w x d)

34.06in x 72.05in x 39.45in (h x w x d)

#### WEIGHT

800 kg (1763.7 lbs)



## Part of the Auger Torque landscaping range

**STUMP PLANERS | LOG SPLITTERS | MULCHERS | HEDGE TRIMMERS | SWEEPER  
BROOMS**